

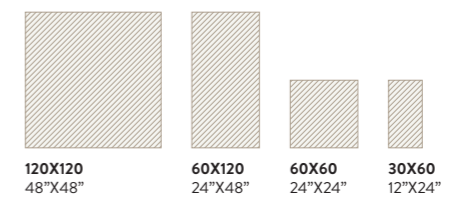

# CONCRETE PROJECT

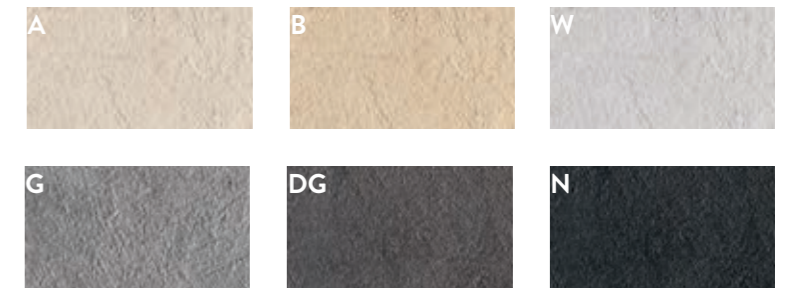

**GRES PORCELLANATO A TUTTO SPESSORE**  
FULL BODY PORCELAIN TILE



CONCRETE PROJECT

CONPROJ120DG

CONPROJ120G



CONCRETE PROJECT

CONPROJ120DG

CONPROJ120G





CONCRETE PROJECT





# CONCRETE PROJECT

GRES PORCELLANATO A TUTTO SPESSORE / FULL BODY PORCELAIN TILE  
 ISO 13006 - G - Bia UGL (E ≤ 0,5%) UNI EN 14411 - G

CONCRETE PROJECT



**A**



**B**

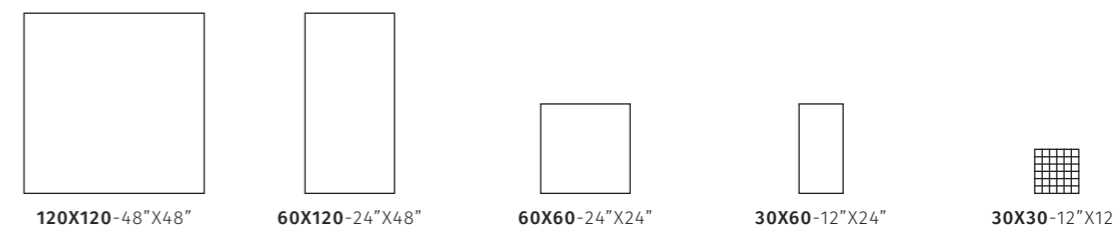
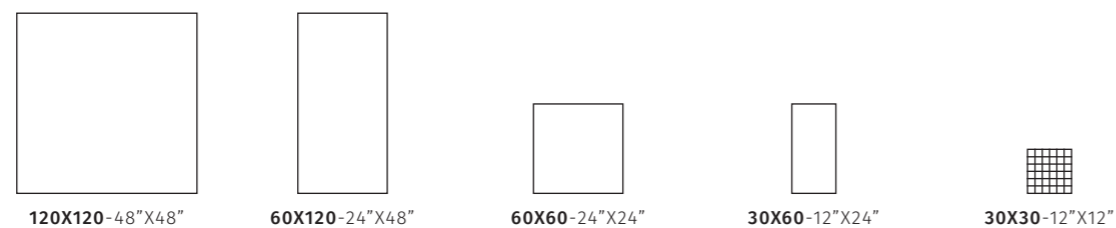

			CONPROJ 120A	CONPROJ 12A	CONPROJ 60A	CONPROJ 36A	MK.CONPROJ 30A
			CONPROJ 120A LP	CONPROJ 12A LP	CONPROJ 60A LP	CONPROJ 36A LP	
					CONPROJ RB60A	CONPROJ RB36A	

			CONPROJ 120B	CONPROJ 12B	CONPROJ 60B	CONPROJ 36B	MK.CONPROJ 30B
			CONPROJ 120B LP	CONPROJ 12B LP	CONPROJ 60B LP	CONPROJ 36B LP	
					CONPROJ RB60B	CONPROJ RB36B	



MU.CONPROJ 36A  
 30X60 - 12"X24" △

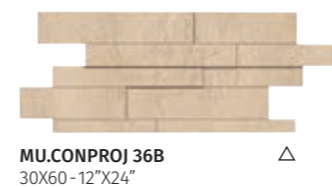

MU.CONPROJ 36B  
 30X60 - 12"X24" △



# CONCRETE PROJECT

GRES PORCELLANATO A TUTTO SPESSORE / FULL BODY PORCELAIN TILE

ISO 13006 - G - Bia UGL (E ≤ 0,5%) UNI EN 14411 - G

CONCRETE PROJECT



## W



## G

LI	N			
CONPROJ 120W	CONPROJ 12W	CONPROJ 60W	CONPROJ 36W	MK.CONPROJ 30W
LI	LP			
CONPROJ 120W LP	CONPROJ 12W LP	CONPROJ 60W LP	CONPROJ 36W LP	
RB	N			
		CONPROJ RB60W	CONPROJ RB36W	

LI	N			
CONPROJ 120G	CONPROJ 12G	CONPROJ 60G	CONPROJ 36G	MK.CONPROJ 30G
LI	LP			
CONPROJ 120G LP	CONPROJ 12G LP	CONPROJ 60G LP	CONPROJ 36G LP	
RB	N			
		CONPROJ RB60G	CONPROJ RB36G	

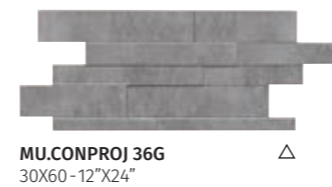

# CONCRETE PROJECT

GRES PORCELLANATO A TUTTO SPESSORE / FULL BODY PORCELAIN TILE  
 ISO 13006 - G - Bia UGL (E ≤ 0,5%) UNI EN 14411 - G

CONCRETE PROJECT



## DG



## N

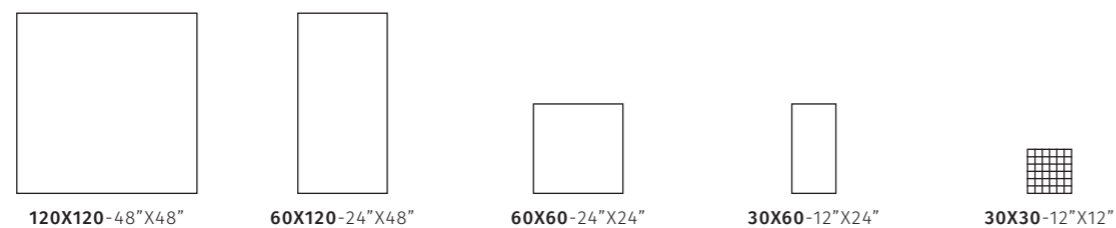

		CONPROJ 120DG	CONPROJ 12DG	CONPROJ 60DG	CONPROJ 36DG	MK.CONPROJ 30DG
		CONPROJ 120DGLP	CONPROJ 12DGLP	CONPROJ 60DGLP	CONPROJ 36DGLP	
				CONPROJ RB60DG	CONPROJ RB36DG	

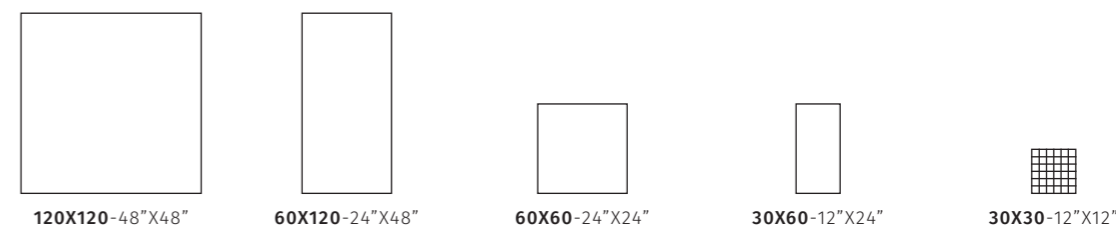

		CONPROJ 120N	CONPROJ 12N	CONPROJ 60N	CONPROJ 36N	MK.CONPROJ 30N
		CONPROJ 120N LP	CONPROJ 12N LP	CONPROJ 60N LP	CONPROJ 36N LP	
				CONPROJ RB60N	CONPROJ RB36N	



MU.CONPROJ 36DG  
 30X60 - 12"X24" △



MU.CONPROJ 36N  
 30X60 - 12"X24" △

# CONCRETE PROJECT





GRES PORCELLANATO A TUTTO SPESSORE / FULL BODY PORCELAIN TILE

ISO 13006 - G - Bia UGL (E ≤ 0,5%) UNI EN 14411 - G

CONCRETE PROJECT



## PEZZI SPECIALI / SPECIAL PIECES

				
	9,5X60-3.7"X24" △	60X120-24"X48" △	120X32,5-48"X12.8" △	120X32,5-48"X12.8" △
<b>A</b>	CONPROJ BT 60A	CONPROJ KIT 12A	CONPROJ G120A	CONPROJ A120ADX CONPROJ A120ASX
<b>B</b>	CONPROJ BT 60B	CONPROJ KIT 12B	CONPROJ G120B	CONPROJ A120BDX CONPROJ A120BSX
<b>W</b>	CONPROJ BT 60W	CONPROJ KIT 12W	CONPROJ G120W	CONPROJ A120WDX CONPROJ A120WSX
<b>G</b>	CONPROJ BT 60G	CONPROJ KIT 12G	CONPROJ G120G	CONPROJ A120GDX CONPROJ A120GSX
<b>DG</b>	CONPROJ BT 60DG	CONPROJ KIT 12DG	CONPROJ G120DG	CONPROJA120DGDG CONPROJA120DGSX
<b>N</b>	CONPROJ BT 60N	CONPROJ KIT 12N	CONPROJ G120N	CONPROJ A120NDX CONPROJ A120NSX



CONPROJ 12A LP

## CARATTERISTICHE TECNICHE SPECIFICHE / TECHNICAL FEATURES SPECIFICATIONS

	DIN 51130 (R)	DIN 51097 (A+B+C)	BCR REP. CEC 6/81		DM 14/6/89 N. 236		PENDULUM TEST BS (INGLESE)	PENDULUM TEST AS/NZS 4856:2004 (AUSTRALIANO)	PENDULUM TEST UNE ENV 12633:2003 (SPAGNOLO)	BOT 3000 (DCOF)
			g.a.	g.b.	c.a.	g.b.				
CONPROJ	R10	A	>0.4	>0.4	>0.4	>0.4	>25	-	1	>0.42
CONPROJ RB	R11	A+B	>0.4	>0.4	>0.4	>0.4	>36	>35	3	>0.42

# SIMBOLOGIA

SYMBOLS

## INDICAZIONI D'USO INDICATIONS FOR USE

 Pavimento  
Floor tiles

 Rivestimento  
Wall tiles

## DESTINAZIONI D'USO SUGGESTED APPLICATIONS

 Abitazioni  
Domestic purpose

 Esterni  
Outdoor floor

 Commerciale leggero  
Tiles for light commercial

 Commerciale pesante  
Tiles for heavy traffic area

## STRUTTURA STRUCTURE

 Liscio  
Flat

 Bocciardato  
Bush-hammered rustic

## FINITURA FINISH

 Naturale  
Natural

 Lappato  
Honed

## STONALIZZAZIONE SHADE VARIATION

 V2

## BORDO EDGE

 Rettificato monocalibro  
Monocaliber, rectified

## CARATTERISTICHE DI VENDITA SALES CHARACTERISTICS

 Prodotto venduto al pezzo.  
Product sold per item.

Tutti i nostri prodotti, sia al mq che al pezzo, sono venduti unicamente a scatola completa.  
All our products are sold only in complete boxes, whether the unit of measure is per item or per square metre.

## ASPETTO SUPERFICIALE SURFACE LOOK

 Opaco  
Matt











 Satinato  
Satin finish

## MODULARE MODULAR

 Modulare 2mm  
Modular 2 mm

# CARATTERISTICHE TECNICHE GRES PORCELLANATO

TECHNICAL SPECIFICATIONS PORCELAIN STONEWARE  
UNI EN 14411(ISO 13006) - Bla (appendice G)

CARATTERISTICA SPECIFICATION	METODO DI PROVA TEST METHODS	REQUISITI PREVISTI DALLA NORMA REQUIREMENTS IN ACCORDANCE TO THE STANDARDS	VALORE MEDIO IMOLA CERAMICA IMOLA CERAMICA AVERAGE VALUE
 <b>DIMENSIONI E ASPETTO</b> DIMENSIONS AND APPEARANCE	ISO 10545-2	<b>PROSPETTO G.1</b> PROSPECT G.1	<b>CONFORME</b> COMPLIANT
 <b>ASSORBIMENTO D'ACQUA</b> WATER ABSORPTION	ISO 10545-3	≤ 0,5%	≤ 0,1%
<b>RESISTENZA A FLESSIONE</b> FLEXURAL RESISTANCE		min./MIH 35 N/mm <sup>2</sup>	> 45 N/mm <sup>2</sup>
 <b>SFORZO DI ROTTURA</b> MODULUS OF RUPTURE	ISO 10545-4	<b>SPESORE</b> - THICKNESS ≥ 7,5 mm: min. 700 N <b>SPESORE</b> - THICKNESS < 7,5 mm: min. 1300 N	<b>SPESORE*</b> THICKNESS* 8,5 mm* 2500 N* 12 mm* 5000 N* 14 mm* 6500 N* 20 mm** 11000 N**
<b>RESISTENZA ALL'ABRASIONE PROFONDA</b> DEEP ABRASION RESISTANCE	ISO 10545-6	≤ 175 mm <sup>3</sup>	< 140 mm <sup>3</sup>
 <b>RESISTENZA ALL'ABRASIONE SUPERFICIALE</b> RESISTANCE TO SURFACE ABRASION	ISO 10545-7	<b>CLASSI 0-5</b> CLASSES 0-5	<b>COME INDICATO IN CATALOGO</b> AS INDICATED IN THE CATALOGUE
 <b>COEFFICIENTE DILATAZIONE TERMICA LINEARE (A)</b> LINEAR EXPANSION THERMIC COEFFICIENT	ISO 10545-8	<b>METODO DISPONIBILE</b> AVAILABLE ON REQUEST	≤ 7X10 <sup>-6</sup> °C <sup>-1</sup>
 <b>RESISTENZA AGLI SBALZI TERMICI</b> RESISTANCE TO SUDDEN TEMPERATURE CHANGES	ISO 10545-9	<b>METODO DISPONIBILE</b> AVAILABLE ON REQUEST	<b>RESISTE</b> RESISTANT
 <b>RESISTENZA AL GELO</b> FROST RESISTANCE	ISO 10545-12	<b>RICHIESTA</b> ALWAYS TESTED	<b>RESISTE</b> RESISTANT
 <b>PRODOTTI CHIMICI AD USO DOMESTICO ED ADDITIVI PER PISCINA</b> HOUSEHOLD CHEMICALS AND SWIMMING POOL WATER CLEANSERS	ISO 10545-13	<b>UGL</b> min. UB <b>GL</b> min. GB	<b>UGL</b> min. UB <b>GL</b> min. GB
<b>ACIDI ED ALCALI A BASSA CONCENTRAZIONE</b> ACIDS AND LOW CONCENTRATION ALKALIS		<b>UGL</b> DA ULA, ULB A ULC FROM ULA, ULB TO ULC <b>GL</b> DA GLA, GLB A GLC FROM GLA, GLB TO GLC	<b>UGL</b> DA ULA, ULB A ULC FROM ULA, ULB TO ULC <b>GL</b> DA GLA, GLB A GLC FROM GLA, GLB TO GLC
<b>ACIDI ED ALCALI AD ALTA CONCENTRAZIONE</b> ACIDS AND HIGH CONCENTRATION ALKALIS		<b>METODO DISPONIBILE</b> AVAILABLE ON REQUEST	<b>METODO DISPONIBILE</b> AVAILABLE ON REQUEST
 <b>RESISTENZA ALLE MACCHIE</b> STAIN RESISTANCE	ISO 10545-14	<b>METODO DISPONIBILE</b> AVAILABLE ON REQUEST	min. 3
 <b>STABILITÀ DEI COLORI ALLA LUCE</b> COLOUR STABILITY TO LIGHT	DIN 51094	<b>NON DEVONO PRESENTARE APPREZZABILI VARIAZIONI DI COLORE</b> THEY DO NOT HAVE TO SHOW VISIBLE COLOUR ALTERATION	<b>CONFORME</b> COMPLIANT

\*SPessori riferiti al formato 20X20 - THICKNESSES REFERRED TO 20X20 SIZE

\*\*SPessori riferiti al formato 60X60 - THICKNESSES REFERRED TO 60X60 SIZE



IMOLACERAMICA.IT



CONCRETE PROJECT

---

A brand of  
**Cooperativa Ceramica d'Imola S.c.**

Via V. Veneto, 13  
40026 Imola (BO) Italia  
Tel. +39 0542 601601  
Fax +39 0542 31749

---